

SERVICE MANUAL ROCK MACHINE RM-E01

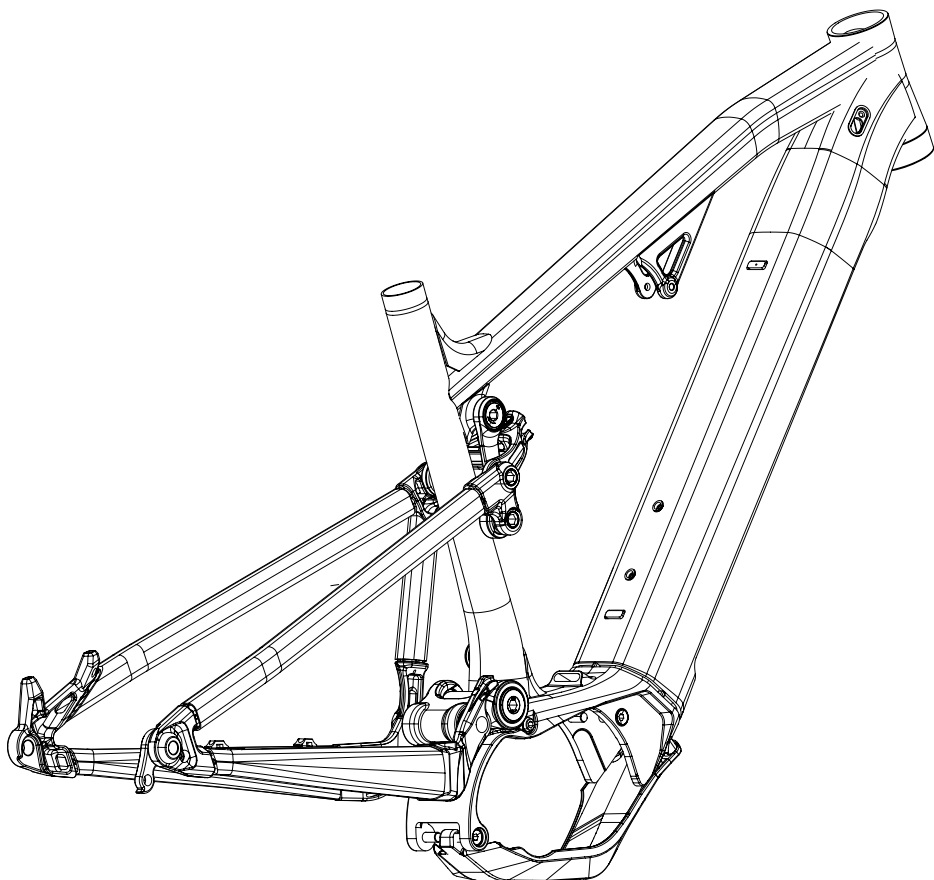

SERVICE MANUAL ROCK MACHINE

Rock Machine would like to congratulate you on the purchase of your new product. We place great emphasis on the choice of materials and their processing so as to ensure the highest quality of our products, a long service life and great functionality. Our name is a symbol of a captivating design, concept and appearance.

To enjoy unlimited riding pleasure with your high-quality Rock Machine product for many years to come, it is necessary to observe certain rules defined and specified in the Service Manual. You have received the Operating Manual with your bike.

Rock Machine supplies high-quality bicycles exclusively for specialized shops. These products are already partially pre-assembled.

The final assembly of the bike can only be carried out by an authorized Rock Machine dealer. This particularly applies to the basic configuration of suspension components, the front and back derailleurs and braking systems. This will ensure maximum safety when using the product.



WARNING

WARNINGS RELATED TO MECHANICAL WORK

Specialized skills and tools are required to configure and tune the bike. These tasks should only be carried out by employees at an authorized service station. Riding a bike that has not been correctly configured and assembled can be dangerous. Even a seemingly minor deficiency, such as a loose screw, can cause a crucial part to break over time and the loss of control of the bike, leading to an accident. Therefore, we recommend that you leave any repairs and maintenance for your bicycle to an authorized service centre. Your safety depends on the correct maintenance of the bike. Employees of authorized service stations have special qualifications and know-how.



WARNING

Any adjustments and modifications can lead to the frame, fork or other parts becoming unsafe. The use of an unapproved component or the incorrect assembly of parts can lead to excessive wear and tear of the bike or its parts. Adjustments to the frame, fork or other components can have a negative impact on the handling of the bike and may lead to a fall. Do not grind off, drill or file any parts; do not remove backup safety elements, do not install incompatible forks and do not make any other similar unauthorized changes. Before you install any accessories on your bicycle, or replace any part, always consult the service centre staff to make sure the particular accessory or part is compatible and safe to use.

BIKE CATEGORY

e-Blizzard INT2

Mountain bikes are equipped with a rear suspension and are constructed for "standard", "racing", "cross-country" or "singletrack-trail" rides, assuming adherence to type-3 operating conditions:

Type-3 operating conditions

Riding on trails, crossing small obstacles and technical courses of medium difficulty as well as stretches where the tyres do not make contact with the ground for a short period of time; jumps and drops not exceeding 61 cm (24").



PREVENTING DAMAGE

If you are transporting the bike in a box, make sure that the bike is kept safe, for instance by using a soft foam cover. Make sure that there are no foreign items or that excessive pressure or force from these items cannot damage the frame. Please keep in mind that the warranty does not apply to damage caused during transit.

SERVICE INTERVALS

- Large-scale service – at a service centre, 1× per year or after 200 hours of riding.
- Check the tightening of moving parts before and after each ride. The prescribed torques of individual joints (see the diagram below) must be strictly observed.
- Bearings and pivots should be lubricated 1× per half a year.
- Consult your dealer about the exact service plan and maintenance schedule of your bicycle. The dealer shall propose the schedule depending on the model of your bicycle and the way you use it. The service intervals stated above are the recommended maximum intervals for regular bicycle maintenance, i.e. they cannot be extended under any circumstance. If you ride your bicycle more intensively, or if your dealer advises you to, we recommend that you shorten the intervals and extend the scope of tasks carried out. For example, if you ride your bicycle in adverse climatic conditions, over hard terrain or if you have equipped your bicycle with specific components with a different service interval and scope of regular maintenance stated by their manufacturer (exact instructions regarding the service of particular components will be provided by your dealer).



WARNING

The warranty may be voided if the service intervals and prescribed torques are not adhered to.

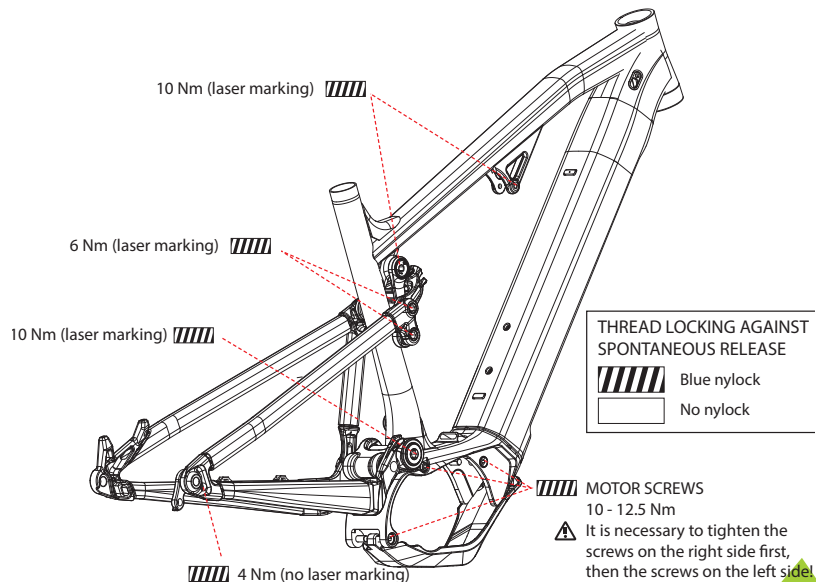

REAR SHOCK AND FORK ADJUSTMENT

CONFIGURING THE FORK AND REAR SHOCK STIFFNESS (SAG)

- Depending on your riding style and the way you use your bike, the sag should range between 20-30%.
- This value is specified directly on the rear shock body or on the inner side of the fork right-hand leg.
- The fork and the rear shock must always be unlocked while being configured.
- Move the rubber indication ring located on the inner fork leg and the rear shock body to the dust cap.
- Sit on the bicycle with your full weight and then get off it carefully, without rocking the bike.
- Check the position of the ring and make sure that the fork and the rear shock are set in accordance with the values stated in the chart (see below), or adjust the pressure in the fork as needed.

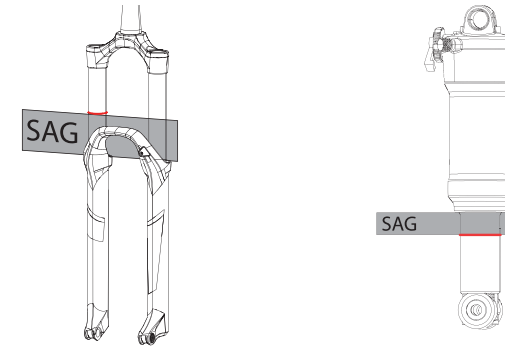

SETTING THE REBOUND FOR THE FORK AND SHOCK ABSORBER

- Rebound is a term used to describe the speed of the fork or rear shock returning to its original position after absorbing a shock. The control for adjusting the rebound is usually located on the can of the rear shock or at the lower end of the fork leg.
- When sitting on the saddle, ride off an edge of approx. 10 -15 cm in height.
- If the shock rocks 1 or 2 times, the rebound is set correctly.
- If the shock rocks more than 3 times, the rebound is too fast.
- If the shock does not rock at all, the rebound is too slow.

SERVICE

REPLACING THE CABLES AND HOSES

Ducts are made using guiding tunnels inside of the bicycle frame. The ducts allow easy and quick replacement of cables and hoses within their full length without need to break them.

1 REPLACING THE REAR DERAILLEUR CABLE

- 1.1 Slide the old cable out from the guide in the frame.
- 1.2 Slide a new cable in the frame through the hole **A1** and pull it out through the hole **A2**.
- 1.3 Fix the cable to the hitch **A3** using a tying strip.
- 1.4 Slide the cable through the hole **A4** in the rear swingarm and pull it out through the hole **A5**.

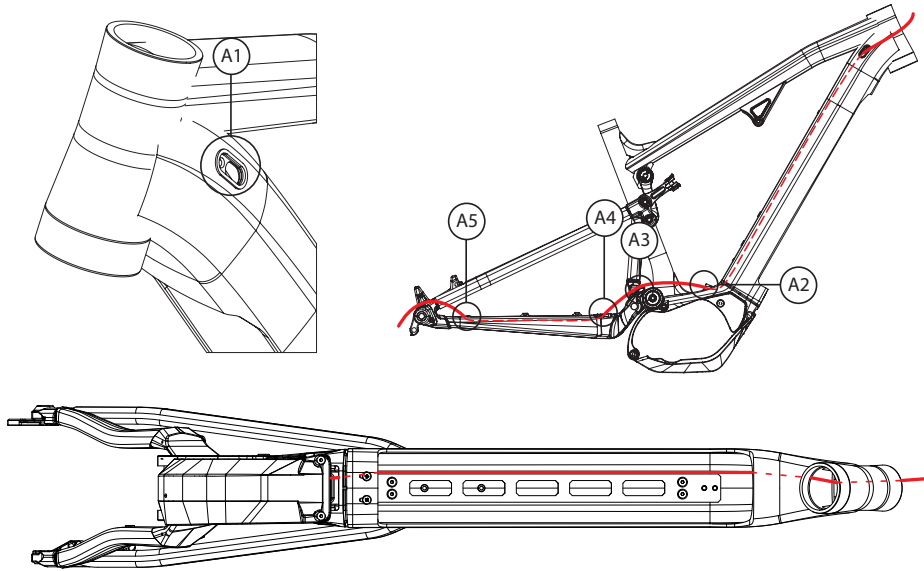

2 REPLACING THE HYDRAULIC HOSE OF THE REAR BRAKE

- 2.1 Slide the old hose out from the guide in the frame.
- 2.2 Slide a new hose in the frame through the hole **A1** and pull it out through the hole **A2**.
- 2.3 Fix the cable to the hitch **B1**.
- 2.4 Fix the cable to the hitches **B2** and **B3** using tying strips.

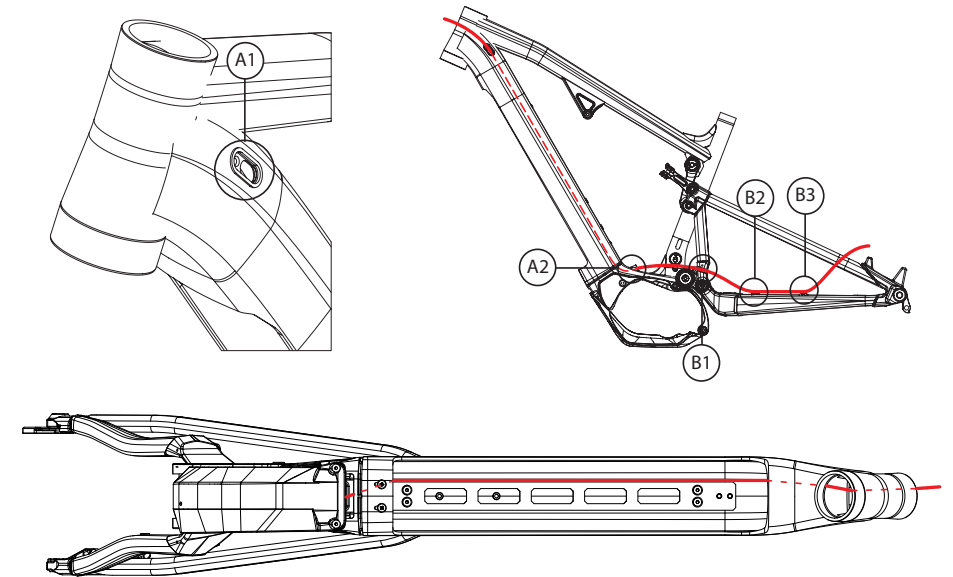

3 REPLACING THE TELESCOPIC SEATPOST CABLE

- 3.1 Slide the old cable out from the guide in the frame.
- 3.2 Slide a new cable in the frame through the hole **C1** and pull it out through the hole **A2**.
- 3.3 Slide the cable in through the hole **C2** and pull it through the seatpost tube.

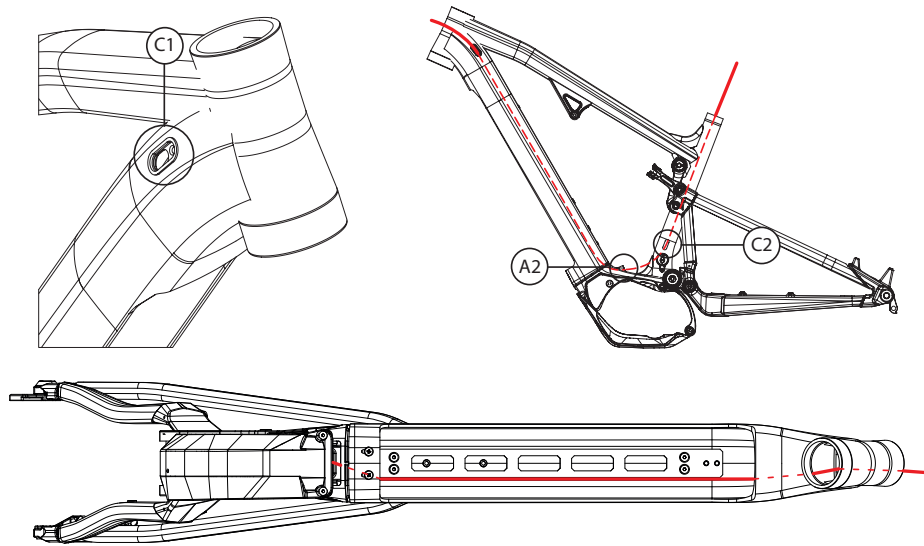

4 FASTENING THE CABLES, HYDRAULIC HOSE AND DISPLAY CABLE

- 4.1 Fasten the cables, hydraulic hose and display cable to the docking station bar using tying strips.
- 4.2 Tighten the telescopic seatpost cable so that it would remain movable.
- 4.3 Put the foam **Jagwire SFA07A5M** sleeve on the cables, hydraulic hose and display cable in length only up to the headset.

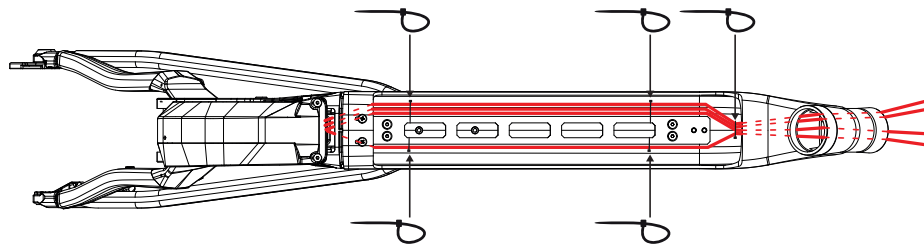

5 PULLING THE CABLES, HYDRAULIC HOSE AND DISPLAY CABLE THROUGH THE HEADSET AND SPACER RINGS

- 5.1 Pull the cables, hydraulic hose and display cable through the headset bearing lid and spacer rings so that the telescopic seatpost cable and display cable would be positioned on the right-hand side when viewing from the front **(1)**.
- 5.2 Pull the shifting cable and rear brake hydraulic hose through so that they would be positioned on the left-hand side when viewing from the front **(2)**.

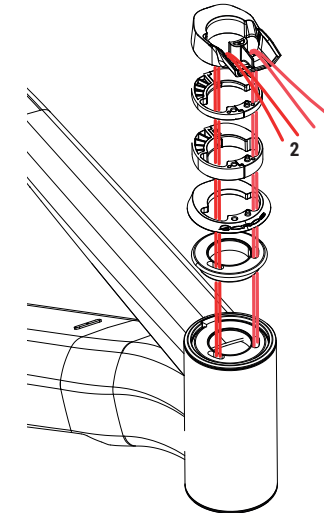

COMPATIBILITY

Brake Rotors	Front	Ø 180 - 203 mm
	Rear	Ø 180 - 203 mm
Tyre		max. 29" x 2,6"
Chainring	1x	max. number of teeth 36
Headset		BC 1-1/8" *1.5" ACROS AZX-220 ZS44, BLOCK-LOCK
Bottom Bracket		Shimano STePS Middle Drive Unit
Seatpost Clamp		Ø 34.9 mm
Seatpost	Ø 30.9 mm	min. insertion 100 mm
Rear Shock	Travel 140 mm	210 x 55 mm
		Body: 8 x 22.2 mm
		Piston rod: 8 x 14 mm
Rear Thru-axle		Shimano BOOST 12 x 148 mm

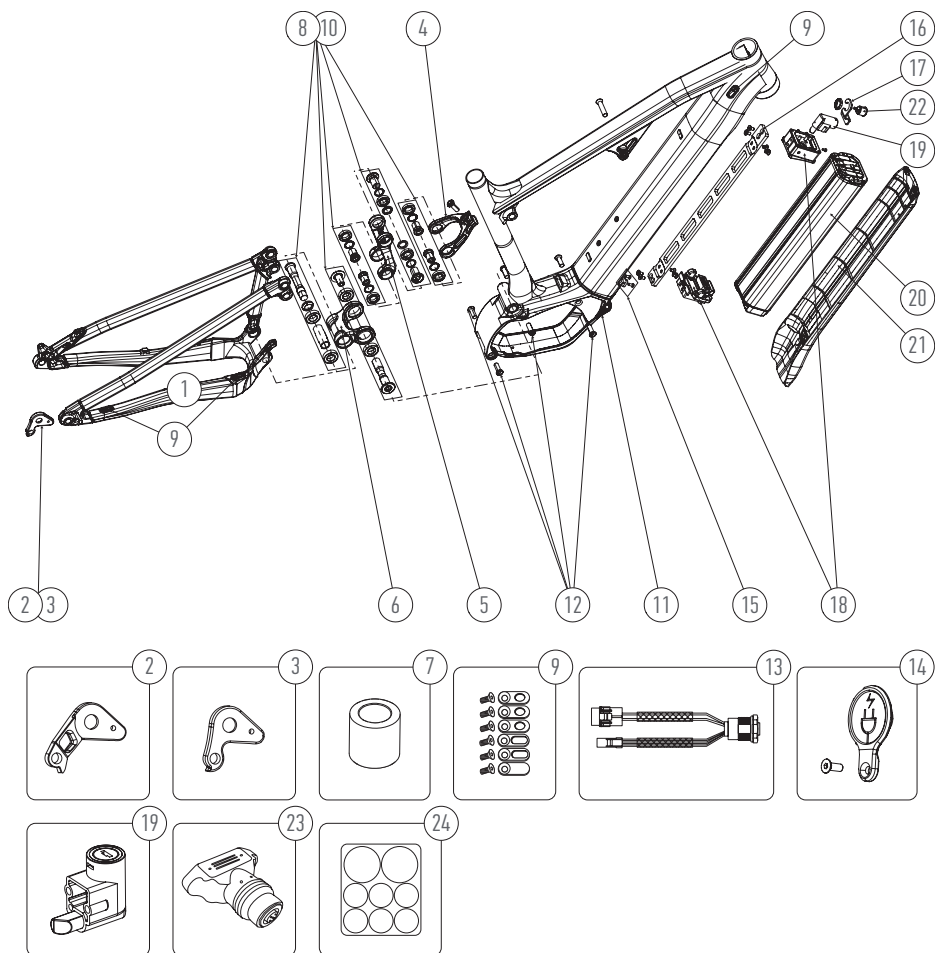

ORIGINAL ACCESSORIES		
ART. NO.	DESCRIPTION	BFI PRODUCT CODE
1	CHAIN STAY PROTECTOR	087.8001.00001-196
2	SHIMANO DIRECT MOUNT DERAILLEUR HANGER	013.0002.00089-377
3	SRAM/SHIMANO DERAILLEUR HANGER	013.0002.00137-372
4	RM SMART LINK UNI - 7134070180003	013.0003.00090-372
5	RM ROCKER LINK - 7321030190003	013.0003.00091-372
6	RM LOW LINK - 7321040060603	013.0003.00094-372
7	SMARTLINK HARDWARE FOR ROCK SHOX REAR SHOCK	006.0000.00188-367
8	BEARING SET [4X 6902V-2RS, 6X 6802V-2RS]	013.0003.00088-372
9	INTERNAL CABLE ROUTING SET	013.0003.00095-372
10	PIVOT AND SCREW SET	013.0003.00096-372
11	SKID PLATE	013.0019.00001-372
12	MOTOR SCREW SET	598.1303.00022
13	CHARGER	095.0008.00019-396
14	CHARGER COVER	095.0010.00023-372
15	COVER LOCKHOLD	013.0017.00016-372
16	DOCK PLATE	095.0010.00018-372
17	POWER SWITCH HANGER	095.0010.00019-372
18	BATTERY MOUNT	095.0013.00022-396
19	BATTERY MOUNT LOCK	098.0002.00093-276
20	BATTERY 503 WH	095.0003.00073-396
21	BATTERY COVER	013.0020.00003-196
22	POWER BUTTON	095.0016.00003-396
23	CHARGING ADAPTER	095.0012.00007-396
24	PROTECTION DECAL SET	087.7000.00009-196



SMART TIPS

To improve handling and comfort and to prevent defects, we recommend installing a tubeless system.

#INTRAILWETRUST

Rock Machine is a registered trade mark of
BIKE FUN International

Areál Tatry 1445/2
742 21 Kopřivnice

www.rockmachine.us